

Actuator

02-
614.011

Distribution by
Farnell



<https://farnell.eao.com/component/02-614.011/...>

Your product:



02-614.011 Actuator

Loading . . .

PRODUCT RANGE

Product Status: Not Recommended for new design

FRONT

Front form: Rectangular

Front bezel colour: Black

Front bezel material: Plastic

MOUNTING

Design: Flush

Mounting cut-out: 21.2 mm x 29.2 mm

Mounting type: Panel mounting

OPERATING-/INDICATION PART

Lens illumination: Non illuminated

ELECTRICAL CHARACTERISTICS

Switching voltage and switching current: according to UL
250 VAC, 10 A
according to IEC 60947-5-1
AC-12: 400 V, 10 A
AC-15: 250 V, 8 A
DC-13: 60 V, 1 A
AC-15: 400 V, 6 A
DC-13: 110 V, 0.4 A
DC-13: 24 V, 3 A

Contacts: 2 C

Rated insulation voltage Ui: 400 VAC/440 VDC according to IEC 60947-5-1

Switching rating: 400 V @ 10 A

Electric strength:	2500 VAC, 50 Hz, 1 minute, as per IEC 60947-5-1 between all terminals and earth
Standards:	The switches comply with the "Standards for low-voltage switching devices" EN IEC 60947-5-1
Thermal current I_{th}:	10 A

MECHANICAL CHARACTERISTICS

Terminal:	Screw terminal
Contact material:	Silver
Switching action:	Maintained
Switching system:	Snap-action switching element
Switching system:	1 or 2 self-cleaning snap action switching elements. 1 or 2 double-throw contacts.
Mechanical lifetime:	1 Mil. cycles of operation
Operating force:	6 ... 12 N
Operating Travel:	ca. 5 mm
Tightening torque:	Fixing nut max. 0.2 Nm, Screw terminal 0.8 Nm
Terminal details 1:	Max. wire cross-section 2 mm x 2.5 mm ² Max. wire cross-section of stranded cable 2 x 1.5 mm ²
Weight:	0.05 kg

AMBIENT CONDITION

IP Protection:	IP40 front side, IP65 with spray cover, according to IEC 60529
Operating temperature:	- 25 °C ... + 55 °C, mounted as a block, make sure the heat can escape freely
Storage temperature:	- 30 °C ... + 85 °C
Shock resistance:	15 g for 11 ms, according to IEC 60068-2-27
Vibration resistance:	10 g at 10 Hz...2000 Hz, amplitude 1.0 mm, according to IEC 60068-2-6

CERTIFICATE

Approbations:	CB (IEC 60947-5-1), CENELEC CCA-NTR (EN 60947-5-1), CSA, DNV, SEV, UL
Conformities:	CE, UKCA, 2011 / 65 / EC (RoHS), 2014 / 35 / EU (LVD)
REACH:	REACH compliant
RoHS:	RoHS compliant

OTHER

Short Description:

Actuator, 21.2 mm x 29.2 mm, Non illuminated, Rectangular, Black, Plastic, 2 C, Maintained, Screw terminal

Housing colour:

Black

Housing material:

Plastic

Wiring diagrams:

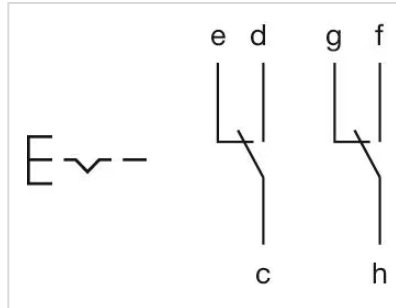

Mounting cut-outs:

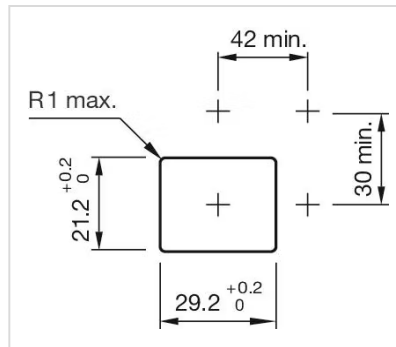

Dimension drawings:

