

Hold-down unit

02-908.7

Distribution by
Farnell

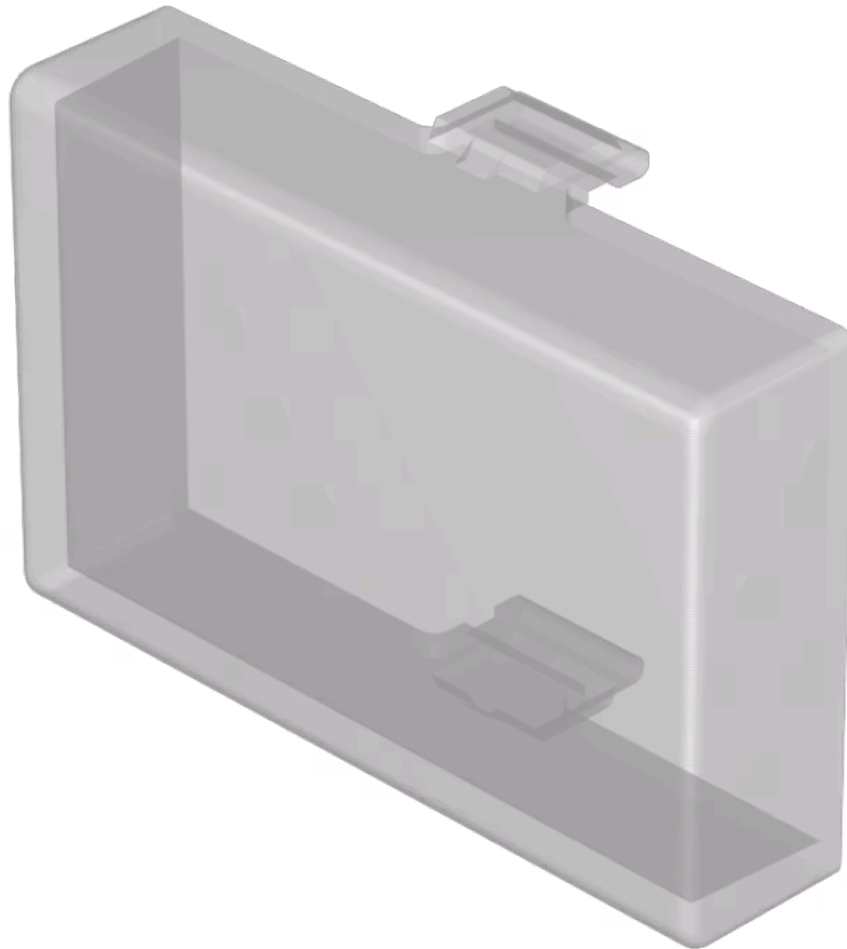

Your product:



02-908.7 Hold-down unit

Loading ...

PRODUCT RANGE

Product Status: Not Recommended for new design

FRONT

Colour: Colourless

ELECTRICAL CHARACTERISTICS

Forward voltage:

MECHANICAL CHARACTERISTICS

Weight: 0.001 kg

OTHER

Short Description: Hold-down unit, Plastic, transparent, Colourless

Titel Accessory: Hold-down unit

Material: Plastic

Hints: For lens with film insert

Optics: transparent