

PCB plug-in base

31-940

Distribution by
Farnell

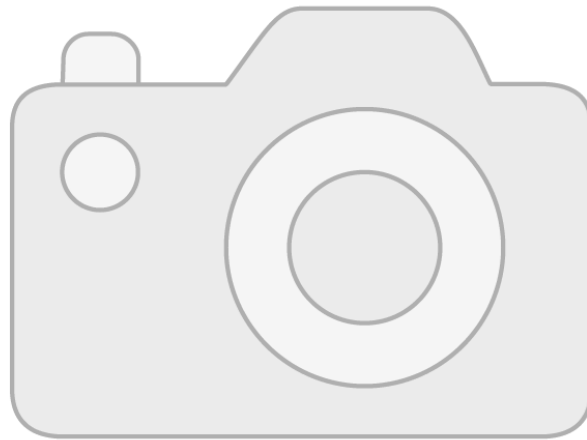

Image not available



Your product:



Image not available

31-940 PCB plug-in base

Loading ...

MECHANICAL CHARACTERISTICS

Terminal: PCB terminal

Weight: 0.011 kg

OTHER

Short Description: PCB plug-in base, PCB terminal, Axial

Titel Accessory: PCB plug-in base

Product attributes: For low level switching element

Pins: Axial

Component layouts:

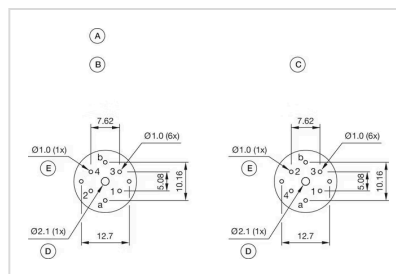

A = Axial socket
B = Drilling-/occupancy plan (component side)
C = Drilling-/occupancy plan diode block
D = for central mounting with M2 screw, if desired
E = non-metallic

Dimension drawings:

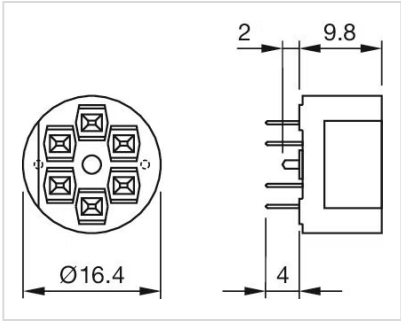

for Part No. 31-940