

Protection cover

45-50F.1100

Distribution by
Farnell



<https://farnell.eao.com/component/45-50F.1100...>

Your product:



45-50F.1100 Protection cover

FRONT

Colour: Colourless

MECHANICAL CHARACTERISTICS

Weight: 0.006 kg

OTHER

Short Description: Protection cover, Silicone, transparent, Colourless

Titel Accessory: Protection cover

Material: Silicone

Product attributes: For keylock switch

Optics: transparent

Dimension drawings:

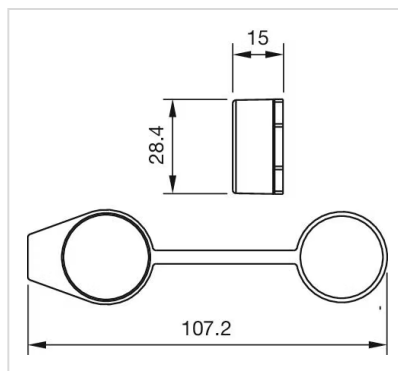

for Part No. 45-50F.1100