

# Protective shroud

45-50Q.2100

Distribution by  
Farnell



<https://farnell.eao.com/component/45-50Q.2100...>

Your product:

---



## 45-50Q.2100 Protective shroud

*Loading ...*

### FRONT

**Colour:** Silver

### MECHANICAL CHARACTERISTICS

**Weight:** 0.02 kg

### OTHER

**Short Description:** Protective shroud, Ø 46.4 mm, Metal, Silver

**Titel Accessory:** Protective shroud

**Dimension:** Ø 46.4 mm

**Material:** Metal

**Dimension drawings:**

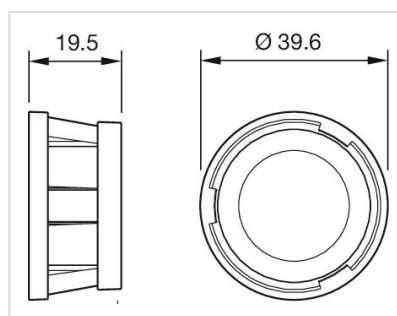

for Part No. 45-50Q.2100