

Diode block 1N4007

704.942.5P

Distribution by
Farnell

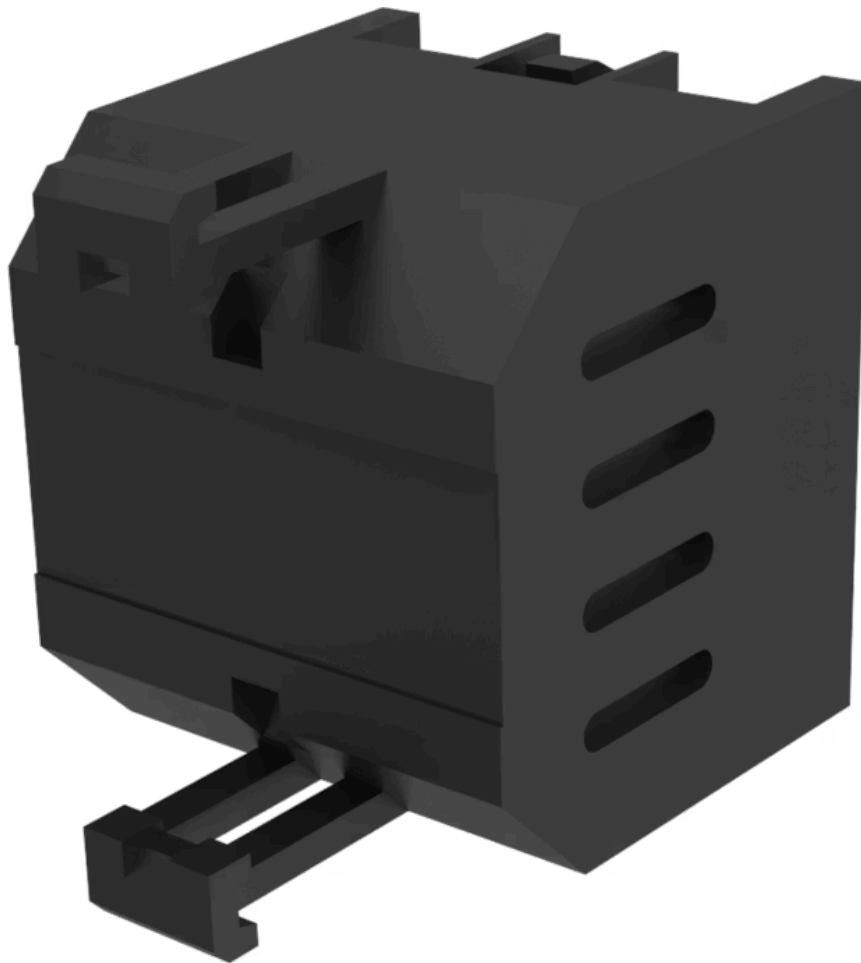

<https://farnell.eao.com/component/704.942.5P/...>

Your product:



704.942.5P
Diode block 1N4007

MECHANICAL CHARACTERISTICS

Terminal: Push-in terminal

Weight: 0.015 kg

OTHER

Short Description:

Diode block 1N4007, Push-in terminal

Titel Accessory:

Diode block 1N4007

Wiring diagrams:

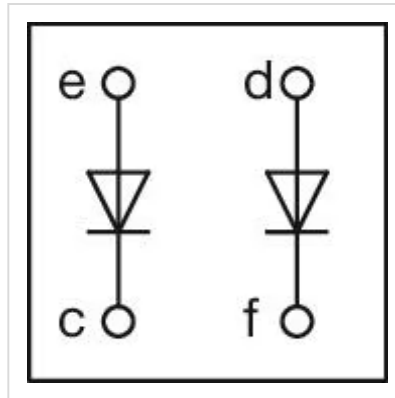

Dimension drawings:

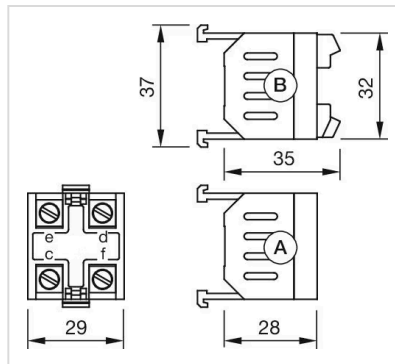

A = Screw terminal
Push-in terminal (PIT)