

# Lamp block

704.951.1

Distribution by  
Farnell



<https://farnell.eao.com/component/704.951.1/e...>

Your product:

---



## 704.951.1 Lamp block

### ELECTRICAL CHARACTERISTICS

**Standards:** The switches comply with the "Standards for low-voltage switching devices" DIN EN 60947-1/DIN EN 60947-5-1

### MECHANICAL CHARACTERISTICS

**Terminal:** Plug-in terminal, 6.3 x 0.8 mm

**Switching positions:** 3 positions

**Wire cross section:** Plug-in terminal 1 x 6.3 mm x 0.8 mm or 2 x 2.8 mm x 0.8 mm  
For switches with plug-in terminals it is necessary to provide insulation sleeves and to maintain a spacing of 65 mm between rows (mounting cut-outs).

**Weight:** 0.014 kg

### AMBIENT CONDITION

**IP Protection:** IP00

**Operating temperature:** - 40 °C ... + 55 °C

**Storage temperature:** - 40 °C ... + 85 °C

**Shock resistance:** Max. 300 m/s<sup>2</sup>, pulse width 11 ms (sinusoidal EN IEC 60068-2-27)

**Vibration resistance:** Max. 100 m / s<sup>2</sup> from 10 Hz ... 500 Hz, (sinusoidal EN IEC 60068-2-6)

**Climate resistance:** Relative humidity, max. 95%, non-condensing

### CERTIFICATE

**REACH:** REACH compliant

**RoHS:** RoHS compliant

### OTHER

**Short Description:**

Lamp block, Plastic, Plug-in terminal, 6.3 x 0.8 mm

**Housing material:**

Plastic

**Hints:**

When using the lamp block, the application guidelines must be observed.

**Wiring diagrams:**

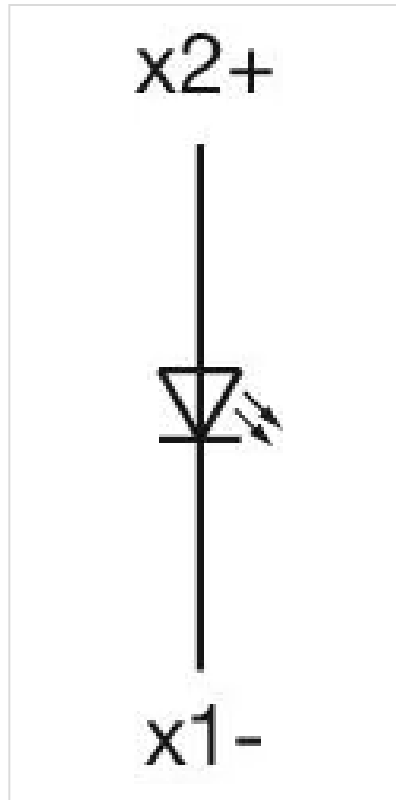

**Dimension drawings:**

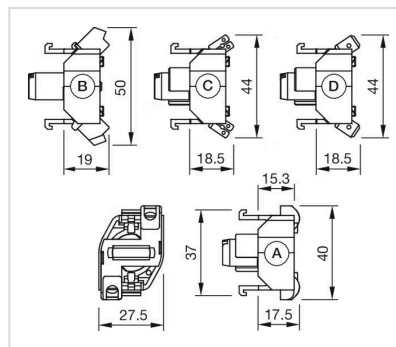

- A = Screw terminal
- B = Push-in terminal (PIT)
- C = Plug-in terminal 6.3 mm x 0.8 mm
- D = Double plug-in terminal 6.3 mm x 0.8 mm