

# Indicator element

92-800.042

Distribution by  
Farnell



<https://farnell.eao.com/component/92-800.042/...>

Your product:

---



## 92-800.042 Indicator element

*Loading ...*

### MECHANICAL CHARACTERISTICS

<b>Terminal:</b>	PCB terminal
<b>Weight:</b>	0 kg

### CERTIFICATE

<b>REACH:</b>	REACH compliant
<b>RoHS:</b>	RoHS compliant

### OTHER

<b>Short Description:</b>	Indicator element, PCB terminal
<b>Material:</b>	Plastic
<b>Hints:</b>	The customer has to decide what series resistor shall be used to the LED LED and mounting flange to be ordered separately
<b>Wiring diagrams:</b>	

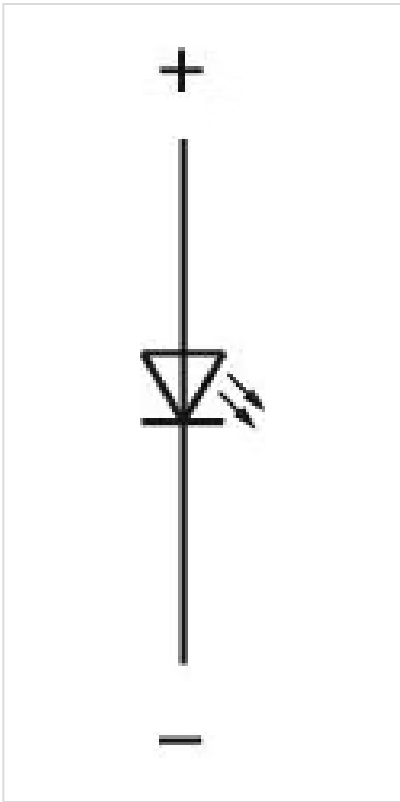

**Component layouts:**

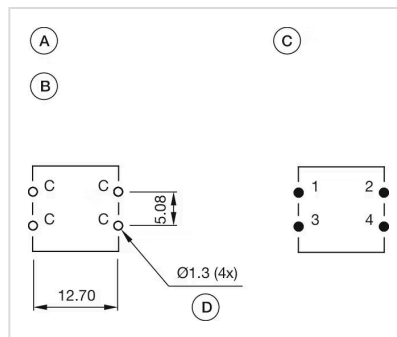

- A = Switching element without illumination
- B = Drilling plan (component side)
- C = Occupancy plan (component side)
- D = Hole for switching element

**Dimension drawings:**

